

## T-Handle and Push Button Shifters

The T-Handle and Push Button shifters are time proven designs for rugged operation in trucks and buses. They have flexible options available and the T-Handle can be custom assembled by many of our F.A.S.T. distributors.



### SPECIFICATIONS

- Lamp Illumination: 14 volts, orange lens
- Switches: ball type, see options for Neutral and /or Reverse
- Travel: 3 inches
- Cable Connection: 4 series (1/4-28) or 6 series (5/16-24)
- Cable entry: Push or pull to reverse, 4 hanger positions
- "2nd Neutral" type available for Allison Transmissions

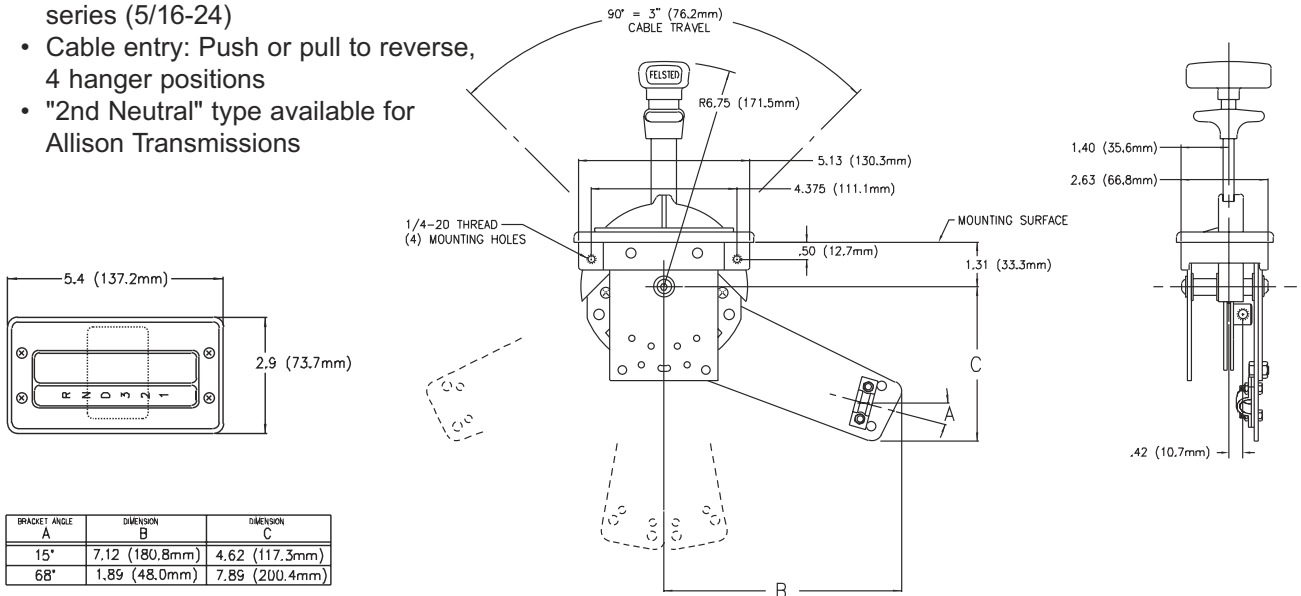

BRACKET ANGLE A	DIMENSION B	DIMENSION C
15°	7.12 (180.8mm)	4.62 (117.3mm)
68°	1.89 (48.0mm)	7.89 (200.4mm)

Transmission Models		B A S I C N U M B E R				
		T-Handle	Push Button	Shift Inhibitor	2nd Neutral P-B Shifter	Position Strip
<b>ALLISON</b>	AT 540, AT 545, AT 543 MT 643, MT 647, MT 644 (MT 640)	55051	55751	56051	—	R,N,D,3,2,1
	MT 653 DR CLT 650 (MT 650)	55052	55752	56052	—	R,N,2-5,2-4,2,1
	MT 654 CR, MT 750 CRD CLT 654	55053	55753	56053	—	R,N,1-5,1-4,1-3,1-2,1
	HT 754 CR	—	—	56054	—	R,N,D,4,3,2,1
	V 730	55054	55754	—	—	R,N,D,2,1
	HT 750 DRD CL (B) T 750	55055	55755	56055	—	R,N,2-5,2-4,2-3,2,1
	HT 740, HT 740FS, HT 740RS	55056	55756	56056	—	R,N,D,3,2,1
	AT542N, AT545N AT1542N, AT1545N	—	—	—	55934 mechanical uses cable	P-B,R,N,D,D3,D1
	AT542N, AT545N AT1542N, AT1545N	—	—	—	55946 Electrical	P-B,R,N,D,D3,D1

NEW - AVAILABLE: Allison Transmission, 1000/2000 Series <sup>TM</sup>: Consult Factory

Items listed within yellow field are Felsted Basic Part Numbers. Refer to these when ordering a shifter.  
See page 6 for Shift Inhibitor and 2nd Neutral P-B Shifters.



**M. Knöpfler AG**  
Wiesackerstr. 128  
8105 Regensdorf

Tel: ++41 44 840 62 21  
info@m-knoepfli.com

